

little titanium no precipitate was produced even on prolonged boiling. If the amount of titanium was increased slightly both the titanium and the columbium were completely precipitated by the disodium hydrogen phosphate. This reagent, therefore, does not separate the two elements.

Geisow found that an alkaline formoxime solution precipitated zirconium and titanium, but did not precipitate columbium.

Formoxime, or its polymerization product, was prepared by bringing together solutions of the calculated quantities of formaldehyde, sodium carbonate, and hydroxylamine hydrochloride. The resulting solution gave no precipitate when added to a solution of titanium as double fluoride, zirconium as double fluoride, or to a solution of columbium double fluoride. Further, after the addition of the formoxime solution, ammonium hydroxide failed to give a precipitate with any of the solutions noted above. It did, however, give a precipitate with tantalum double fluoride, but this was only partial.

The statement of Geisow that titanium and zirconium can be separated from columbium by means of an alkaline formoxime solution was not verified. The precipitation with tantalum is only partial, and not complete as stated by him.

It was noted¹ that potassium iodate gave a complete precipitation in a solution of potassium titanium fluoride, and no precipitate with a solution of columbium double fluoride. Potassium iodate, free from periodate, was prepared, and it was found to give no precipitate with either columbium or titanium, except in acid solution, when both were precipitated. A solution of a periodate was not tried.

UNIVERSITY OF PENNSYLVANIA.

[CONTRIBUTION FROM THE JOHN HARRISON LABORATORY OF CHEMISTRY, No. 97.]

ELECTROLYTIC CALCIUM.

BY JOSEPH H. GOODWIN.

Received August 28, 1905.

METALLIC calcium can be easily made in large quantities as shown by the following experiments which required only a short time and simple and easily constructed apparatus. The method

¹ This Journal, 26, 1248.

used was the electrolysis of fused calcium chloride with a hollow cylindrical anode vessel of Acheson graphite (Fig. 1). At first



Fig. 1.

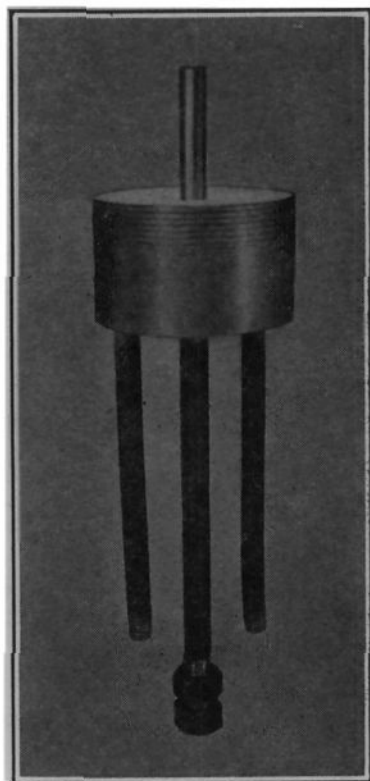

Fig. 2.

the bottom was closed by a smaller iron cylinder insulated from the graphite by asbestos, cooled by circulating water in it and having an iron rod projecting upward through its centre to form the cathode (Fig. 2). This was discarded because the calcium (1) often short-circuited the furnace by the formation of spongy metal, (2) was obtained in small pieces, (3) was difficult to remove, and (4) was surrounded by molten calcium chloride with which it combined, greatly lowering the current efficiency. In connection with this form of cathode an attempt was made to use a cylinder of fine iron gauze to collect and retain the molten calcium, like the nickel gauze in the Castner sodium furnace, but the long-continued action of 225 amperes would not fill this gauze with calcium because it presented a large surface for the rapid recombination of the calcium: $\text{Ca} + \text{CaCl}_2 = 2\text{CaCl}$.¹ The formation of calcium and chlorine almost ceases and active re-

¹Borcher's "Elektro-Metallurgie," 1896, p. 78.

action and circulation are seen to take place in the molten electrolyte.

In the satisfactory furnace (Fig. 3) the bottom of solid calcium chloride was maintained by the cooling effect of a copper coil (E,

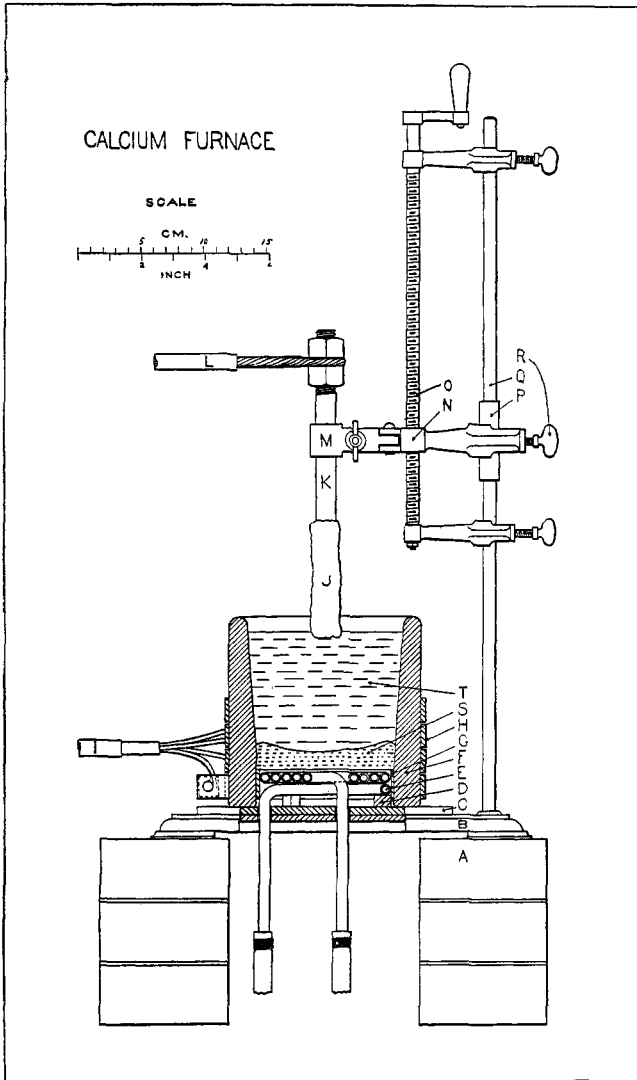

Fig. 3.

Fig. 3 and Fig. 4) through which water was circulated. This coil



Fig. 4.

was insulated from the graphite by asbestos, but a Weston milliammeter indicated that it was carrying 0.17 ampere of the anode current (190 amperes); therefore, to prevent contamination of the bath by copper, a gravity cell (B, Fig. 5) was connected between the copper and the graphite and the milliammeter indicated 0.04 ampere flowing the other way. This very simple and efficient cooling coil was made by annealing four feet of $\frac{5}{16}$ -inch seamless copper tube in a Bunsen flame, filling it with sand, plugging the ends and bending it easily into shape by hand.

The new form of cathode was a $\frac{5}{8}$ -inch iron rod (K, Fig. 3), dipping into the bath from above and capable of being raised or lowered by the screw mechanism O. As the calcium was deposited on the end of this iron rod it solidified, due to the cooling effect of the cold upper part, the whole was gradually raised and the calcium itself conducted the current away and formed the cathode, continuing to grow in the shape of an irregular cylinder, J. This is simplicity itself because it accomplishes at once:

(1) A method of making cylinders of calcium up to 4 cm. diameter and of any length desired with this small furnace. (When the limit of the screw is reached the clamp M can be loosened, lowered and a new hold taken.)

(2) Quick removal of the calcium from the molten calcium chloride, which is essential to maintain a fair current efficiency.

(3) Oxidation prevented by a covering of calcium chloride, fine particles being deposited by the bursting of bubbles of chlorine rapidly evolved at the anode.

The furnace is shown in detail in Fig. 3, and all dimensions can be found by reference to the scale. The bricks A support the retort stand B, on which is a thick piece of asbestos, C, holding by the blocks D the copper coil E well up in the Acheson graphite anode F and insulated from it by the asbestos G. The iron bands H conduct the current from the positive cable I to the graphite vessel F. The calcium grows and forms the stick J, which is started by the iron cathode K connected with the negative cable L and supported by the clamp M, which is drilled and tapped at N to receive the screw O by which it can be raised or lowered. P is a tube sliding freely on the rod Q of the retort stand, and against which R is firmly screwed to make the clamp M fairly rigid without interfering with its vertical motion. Fluor-spar covers the copper coil and fills the space about it, while the furnace is filled with calcium chloride which becomes solid at S and is kept molten at T solely by the current passing through the furnace. The whole apparatus was set up inside an empty wind-furnace from which the grate bars had been removed. In this way the escaping chlorine was drawn from the room. Pure anhydrous calcium chloride was used, melted in a Dixon graphite crucible and added from time to time, but this was found to introduce much iron, aluminum and silicon from the clay binding used in the crucible, so that finally the chloride was added cold and melted by drawing an arc from the iron rod K. Thus the furnace was filled sufficiently for a run.

Fig. 5 is a diagram of the circuits. A direct current dynamo

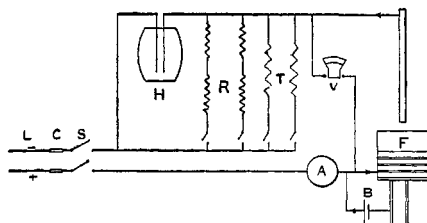

Fig. 5.

supplied the current to the furnace line L at about 95 volts, having 250-ampere fuses at C and a double pole switch at S. Regulating resistance was supplied by a barrel of soda solution,

H, having two 10-inch square cast-iron furnace doors for electrodes and capable of carrying 75 amperes, two pairs of two wire resistance frames R of 75 amperes capacity and 1 ohm resistance per pair in series, two wire resistance frames T of 10 amperes capacity and 8 ohms resistance each. A Siemens 320-ampere ammeter is indicated at A and a 150-volt Weston voltmeter at V. F is the calcium furnace and B the gravity battery to keep the copper coil from carrying any of the anode current. The anode was turned in a lathe from a 6-inch length of Acheson graphite electrode 6 inches in diameter. Being pure and able to withstand the high temperature and chlorine without disintegration, this material is by far the most suitable which can be used for constructing the furnace.

In operation the volts and amperes vary when the cathode is raised, but the following rough furnace record will give a pretty close average of the working conditions:

Run.	Date, 1904.	Volts.	Amperes.	Hours.	Grams calcium.	Current efficiency.
1.....	July 12	20	105		40	
2.....	" 14	15	160	4	200	41.9
3.....	" 15	14	175	8	225	21.5
4.....	" 16	22	125	6	150	26.8
5.....	" 18	19	160	6	295	41.2
6.....	" 21	18	180	5	150	22.3
7.....	" 22	19	185	4	125	22.6
Total.....					1185	

Taking account of the different length of runs and averaging we get for runs 2 to 7:

Average volts.....	=	17.7
" amperes....	=	163.0
" efficiency...	=	29.1 per cent.

On finally weighing the total yield of clean calcium there remained 1050 grams. Adding 35 grams for loss by oxidation, analysis and samples (= 1085 grams), the efficiency becomes

$$29.1 \times \frac{1085}{1185} = 26.6 \text{ per cent.}$$

If covered by an inverted graphite crucible, the furnace can be left cold for more than forty-two hours, and then started again in a couple of minutes without the least trouble by drawing an arc between the iron cathode and graphite anode at the surface of the solid calcium chloride which immediately melts, allowing the iron

end to be immersed and moved slowly to the centre of the furnace as the zone of fusion widens until it soon extends to the graphite on all sides. The sticks of calcium obtained were of irregular shape and covered with chloride. The bright metal showed the following composition, found by an analysis of the piece used in the tension and conductivity tests:

	Per cent.
Si.....	0.03
Fe	0.02
Al.....	0.03
Ca	98.00
Mg.....	0.11
Cl	0.90
O (by difference).....	0.91
	100.00

The product of run No. 5 is shown in Fig. 6. This piece was 56 cm. (22 inches) long 0.8 cm. ($\frac{5}{16}$ inch) least and 3.2 cm. ($1\frac{1}{4}$ inches) greatest diameter, weighed 295 grams and represented a current efficiency of over 40 per cent. Some of the other pieces were of larger diameter. The difficulty experienced until recently in making metallic calcium was probably due to the small scale on which the operation was tried. The simple and satisfactory operation of this furnace would lead one to believe that, technically, the process would be still more efficient and easily controlled. A furnace five times as large, using about 1200 amperes, would require about 8 volts, and the screw mechanism could be electrically controlled, keeping the current constant and the product perfectly uniform, as the rotary furnaces of the Union Carbide Co. are controlled. A water-cooled shield might be necessary to cool the large calcium cathode as it was drawn from the bath. The two essential conditions of operation are:

(1) Rapid withdrawal of the metal formed to increase the yield and minimize recombination.

(2) Narrow temperature limits. The bath must be hot enough to deposit the metal molten, not spongy and must be cool enough to let it congeal upon the cathode and be raised without breaking off.

To clean the metal most of the chloride was broken off with a hammer and the rest dissolved off by leaving the pieces in 95 per cent. alcohol over night. Some hydrogen was evolved but the loss due to this cause was not very great. To keep the metal for a

long time it was put under oil, dipped in melted paraffin or simply put in a dry stoppered bottle.

An attempt was made to fuse several pieces into one big stick. A two-foot length of 1-inch iron pipe was threaded at both ends and a cap screwed firmly on one end. The inside was cleaned with



Fig. 6.

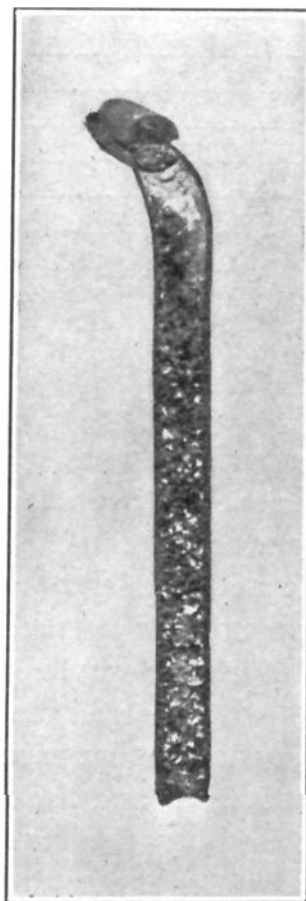

Fig. 7.

dilute sulphuric acid and washed with water, alcohol and ether, and in it were placed about 300 grams of clean pieces of calcium. The whole was heated in a wind furnace to a bright red heat, and on looking down into the tube one could see the red-hot molten metal which was quite fluid as shown by a thick iron wire used as a poker. The upper cap was then screwed on, the tube drawn from the fire, its lower end hit smartly on the cement floor several times, after which the tube was quickly cooled in water. The lower cap was broken off and the walls of the tube cut lengthwise in the milling machine. When torn apart the two halves, split down the centre, displayed a most beautiful mass of large,

reddish violet, cubical crystals (Fig. 7). There was much speculation as to the composition of this peculiar "compound" until the following analysis showed it to be over 90 per cent. calcium:

	Per cent.
Gangue.....	0.03
SiO ₂	0.77
Fe ₂ O ₃	0.46
Al ₂ O ₃	0.77
Ca.....	91.28
Mg.....	0.11
Cl.....	1.28
C.....	trace
N.....	trace
O (by difference).....	5.30
	100.00

The crystals showed a specific gravity of 1.5425 at 28.1° C. In water they evolved hydrogen with an odor of acetylene. Carbon was probably extracted from the iron melting-tube, a reaction which may be of technical importance for converting pig-iron into steel, and the power of calcium to combine with and remove sulphur and phosphorus are very important as is also its strong reducing action on organic compounds, the reaction being more easily controlled and less dangerous than with metallic sodium. These crystals were quite soft and were hammered as thin as paper, often exploding with a slight flame under the impact of the hammer. When filed or cut they showed a brilliant metallic lustre, being not as pure a white as silver but slightly yellow. The solid metal at times has this same slight yellow tint. The crystals near the top of the tube evolved ammonia with water, showing that they had combined with the nitrogen in the melting-tube.

The solid metal can be worked like other metals and is much more stable than imagined. It can be heated red-hot continuously in a triple Bunsen flame without igniting, but at this temperature its texture is like clay and it can be easily squeezed apart with the tongs, sometimes igniting at the edges and burning feebly till the lime formed smothers the flame. When sent whizzing through the air against asbestos, bricks or cement it burns violently with a brilliant white light like magnesium and leaves a streak like antimony. It is not hardened by heating red-hot and plunging into water. At 300-400° C. it is as soft as lead and the irregular sticks can be easily hammered on an anvil, rolled, swaged or worked into

any shape whatever by simply heating from time to time. When cold, a bright calcium surface becomes dull rapidly in ordinary air, but if hot the metal can be brightened with a file or polished in the lathe with emery cloth and will remain bright as long as it is hot. About 300 grams of fine bright specimens were prepared as follows: A glass cylinder and its stopper were put in an air-bath, gradually heated and kept at 150°C . The calcium was kept hot on a stove plate and the pieces polished one at a time and put in the cylinder in the air-bath where they kept bright till all were polished. A little paraffin was rubbed around the stopper and the cylinder closed. In this dry air they have lost none of their lustre and their bright surfaces are as distinctly metallic as those of any other

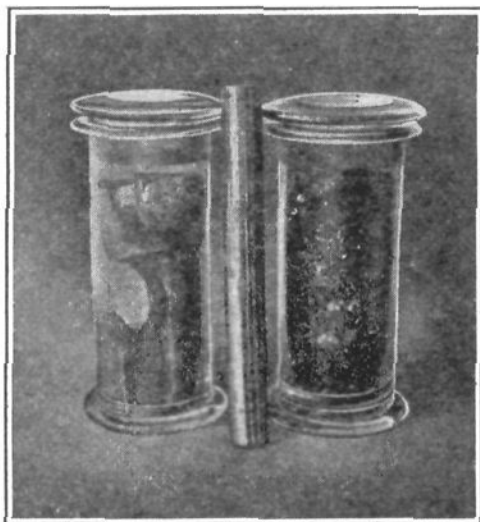

Fig. 8.

metal. Fig. 8 shows the cylinders of crystals and solid metal and a 6-inch stick of polished calcium.

SPECIFIC GRAVITY.

The density of oil was determined by a pycnometer and from weighings of a bright piece of calcium in air, and in this oil its specific gravity was found to be 1.5446 at 29.2°C ., which is compared with some other metals in the following table:

Li.....	0.59	Sb.....	6.76	Ag.....	10.505
K.....	0.87	Zn.....	7.00	Pb.....	11.38
Na.....	0.97	Sn.....	7.35	Hg.....	13.58
Rb.....	1.52	Fe.....	7.93	Au.....	19.258
Ca.....	1.54	Co.....	8.55	Pt.....	21.5
Mg.....	1.74	Cu.....	8.89	Ir.....	22.4
Al.....	2.68	Bi.....	9.82	Os.....	22.5

CONDUCTIVITY.

On the milling machine a piece of calcium about 10 cm. long was accurately finished on the sides and measured 1.43×1.02 cm. It was embedded in a block of wood with a mercury cup at each end and connected through a 15-ampere Weston ammeter, variable resistance and switch with storage batteries. Sharp brass potential points near the ends led to a large, very sensitive, horizontal D'Arsonval galvanometer whose deflections were read by a telescope and scale. The value of the galvanometer deflections in volts was obtained by using a standard low resistance in place of the unknown piece of calcium. The average of several readings gave the resistance between points 7.2 cm. apart 19.4 microhms at 30° C., and 26.7 microhms at 123° C. in a bath of hot paraffin.

Solving the equations

$$R_{30} = R_0 (1 + 30a) = 19.4$$

$$R_{123} = R_0 (1 + 123a)$$

we get the resistance at 0° C.

$$R_0 = 16.94 \text{ microhms}$$

and the temperature coefficient

$$a = 0.00457.$$

Hence the specific resistance at 0° C.

$$= \frac{16.94 \times 1.02 \times 1.43}{7.2} = 3.43 \text{ microhms per cm. cube.}$$

At the mercury cups calcium slowly formed a voluminous amalgam.

In the table below these values for calcium are placed in Sir Roberts-Austen's relative electrical conductivity table and show that calcium is the fifth best conductor, being surpassed by silver, copper, gold and aluminum, if wires of equal diameter and length are compared, but for wires of equal weight and length the order is entirely different, calcium being second and exceeding silver by 67 per cent., copper by 62 per cent., gold by 86 per cent., and aluminum by almost 20 per cent. This method takes into account the specific gravity of the metals and gives the following order of conductivity: sodium, calcium, potassium, aluminum, magnesium, copper, silver, gold, etc. With purer metal still better results are to be expected.

Metal.	Specific residue ° C. microhms per centimeter cube.	Temperature coefficient.	Relative conductivity.	
			Similar area and length.	Similar weight and length.
Ag.....	1.55	0.00377	100.0	32.5
Cu.....	1.59	0.00388	97.6	37.5
Au.....	2.02	0.00365	76.6	13.6
Al.....	2.45	0.00390	63.0	80.4
Ca.....	3.43	0.00457	45.1	100.0
Mg.....	3.92	39.4	75.5
Na.....	5.04 ¹	0.00438 ¹	31.4	115.0
Zn.....	5.22	0.00365	29.6	14.5
Cd.....	6.34	24.4	9.7
K.....	7.01 ¹	0.00581 ¹	22.1	86.8
Co.....	9.15	16.9	6.8
Fe.....	10.6	0.00117	14.6	6.3
Pt.....	10.7	0.00247	14.4	2.3
Sn.....	10.7	0.00365	14.4	6.7
Ni.....	12.0	12.9	5.0
Pd.....	12.8	12.1	3.6
Th.....	16.9	9.1	2.6
Pb.....	18.4	0.00387	8.4	2.5
As.....	33.1	4.7	2.8
Sb.....	43.1	0.00389	3.6	1.8
Hg.....	94.0	0.00093	1.6	0.4
Bi.....	110.0	1.4	0.5

An attempt was made to find the specific heat of calcium, but the results are too poor for publication.

TENSILE STRENGTH.

From the piece of calcium used in the conductivity test a specimen was cut with a hack-saw, finished to 0.458 x 0.135 cm. and marked off into half centimeters. The upper end was gripped in a vise, and to a hand-vise clamped on the lower end a 50-pound weight and empty bucket were freely hung. Sand was poured into the bucket and the specimen broke with a total load of 83.5 pounds, showing a tensile strength of 8,710 pounds per sq. in. or 612 kg. per sq. cm. The elongations in the middle

1 cm.	=	23.0	per cent.
2 "	=	15.0	" "
3 "	=	11.0	" "
5 "	=	6.6	" "

The following table shows the comparative strength of some metals:

¹ A. Bernini: *N. Cimento*, 6, 27, 294 (1903).

Metal.	Ultimate tensile strength.	
	Lbs. per sq. in.	Kg. per sq. cm.
Ag	41,000	2,880
Pt	32,000	2,250
Mg	30,000	2,110
Cu	24,000	1,690
Au	20,000	1,410
Al (cast).....	15,000	1,050
Ca	8,710	612
Zn	7,500	527
Sn	4,600	323
Pb (sheet).....	3,300	232
Bi	3,200	225
Sb	1,000	70.3

Calcium is harder than sodium, lead or tin, almost as hard as aluminum, but softer than zinc, cadmium or magnesium.

The activity with which strontium and barium recombine with their chlorides makes them more difficult to produce. Their production was not tried in the furnace just described. There are many interesting things to be learned about the alkaline earth metals—their isolation, purification and action on gases, solutions, organic compounds, salts, oxides and metals. The question of alloys is a broad one; some might be found of special value because of their electrical conductivity, strength or extreme lightness, calcium being only four-sevenths as heavy as the light metal aluminum. The manufacture of cyanide and peroxide were uses found for metallic sodium, and in like manner uses will be found for calcium. It should be of use in the steel industry and for reduction purposes.

UNIVERSITY OF PENNSYLVANIA.

PREPARATION OF NITROGEN FROM THE ATMOSPHERE.

BY GEO. A. HULETT.

Received September 5, 1905.

NITROGEN is well adapted to operations that require an inert gas or atmosphere, and many methods have been proposed for preparing it. Von Knorre¹ gives a resumé of the methods for preparing nitrogen, and studies the conditions for obtaining it, free of oxides, by heating a solution of sodium nitrite, ammonium sulphate and potassium dichromate. Baxter and Hickley² first prepare oxides of nitrogen which are passed through ammonia

¹ *Chemische Industrie*, 531 and 550 (1902).

² *Am. Chem. J.*, 33, 300 (1905).